

JR-SLT-8Serial single-speed elevator control  
system

User Manual

**Jinan Jieruida Automation Ltd.**

## Directory

I	Overview.....	4
II	Part Description.....	5
2.1	JR-SC-8 Host Controller Description	5
2.1.1	Overall dimensions and the name of operation part	5
2.1.2	Electrical Specifications	6
2.1.3	Electrical connections	6
2.1.4	Terminal Description	6
2.2	Auxiliary Board Application Notes	7
2.2.1	Functional Overview	7
2.2.2	Overall dimensions and components description	7
2.2.3	Terminal Description	8
2.2.4	Internal logic and external connections	9
2.3	The explanation of control panel part	10
2.3.1	The internal structure of the Control Panel	10
2.3.2	Connection Method	11
2.3.3	Terminal Description	11
III	System Application	12
3.1	Main circuit diagram	12
3.2	Auxiliary panel wiring diagram	12
3.3	Control circuit schematic	13
3.4	Control cabinet layout	14
3.5	Control Cabinet Parts List	15
3.6	Terminal control cabinet wiring diagram	15
3.7	Control cabinet terminals description	17
3.8	Control cabinet installation dimensions	17
IV	Commissioning and operation	18
4.1	The initial power-on	18
4.2	Related settings	18
4.2.1	The main control board JR-SC-8 DIP-switch settings	18
4.2.2	The No. settings of control panel	19
4.3	Code instructions	20
4.4	Maintenance Running	20

4.5	Troubleshooting	20
V	Normal operation of the system	21
5.1	Select Layer Running	21
5.2	Smart Intercom	21

## I Overview

JR-SLT-8 is a intelligent single-speed serial communication elevator control system which is developed and produced by **Jinan Jieruida Automation Ltd.** It includes the main controller JR-SC-8, Touch button command controller LTCK-JR, floor displays LTBCD-JR, special auxiliary boards JR-ASB, integrated injection control panel.

Its main feature is:

### 485 Communications:

As a result of 485 bus between the various components of the serial data communication, thus ensuring high-speed, reliable transmission of data in large numbers, while greatly reducing the wiring between the various components. In this way, not only significantly reduce the workload of the production, installation and commissioning, but also improve the reliability of the machine, and save considerable raw materials.

Integrated control panel touch-keys

### **New Smart-to-talk**

It can be achieved between any two floors of intercom calls, intercom status indicators, automatic or manual delay hang up the end of intercom.

SMT Surface Mount Technology

JR-SLT-8 system, have adopted the CPU circuit board SMT surface mount technology. That make the compact CPU board become smaller in size, enhanced reliability and more cost-effective.

Practical instruction code:

The debugging, repair and maintenance of system is on the spot that make it very easy. As the JR-SC-8 main controller is equipped with an intuitive and practical instruction LED digital tube, you can run the elevator fault condition at a glance.

Running protection

This particular includes outbound overtime protection, single station to run overtime protection, wrong to protect and the more stations to provide protection for the elevator to run a self-diagnostic function. For example: When the brake sensor brake failure or damage can lead to outbound overtime, elevator blocked the path will lead to a single station to run out, three-phase power supply fault or phase sequence to the damage can lead to wrong to run sensors, sensor is damaged and the emergence of more stations error of these situations, the above-mentioned of these four functions will be guaranteed a great lift in the case of trouble-free long-term stable operation. the supply of matching

JR-SLT-8 is the main controller and the control panel supporting sales. The main controller power supply module for the control panel module power supply, custom high reliability, internal communication protocol, so completely avoid the non-compliant

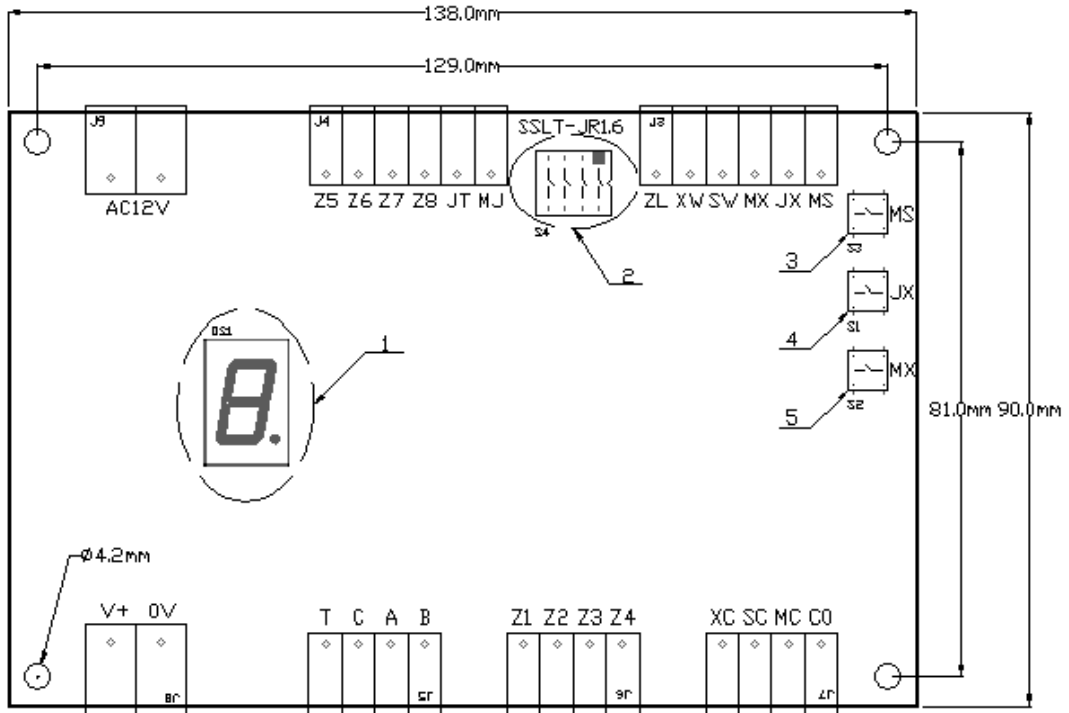

does not match the problem.

The music station clock

The "ding-dong" music of the station clock by the speaker is even be more elegant and upper grades than the traditional buzzer.

## II Part Description

### 2.1 JR-SC-8 Host Controller Description

#### 2.1.1 Overall dimensions and the name of operation part

Specific list of names is as follows

Code	Name	Uses Introduction	Notes
1	Code instructions	Shows fault code and instructions for running	
2	DIP Switch	Set single-station running time and the door adhesion	
3	Slow up	Maintain the up-button	
4	Maintenance	Maintain the key	
5	slow down	Maintain the down-button	

### 2.1.2 Electrical Specifications

Rated input voltage: AC12V

**Scope:** AC12V±0.5V

Input Current: 1.0A (6 layers below) / 1.2A (8 layer)

### 2.1.3 Electrical connections

Power Connection

The work of the main controller power supply should be stable and reliable output switching power supply or transformer power supply, only the need to share 12V (Note: tap transformer output voltage difference can be matched cases: AC36V-AC24V shall AC12V.)

Note:

Switching power supply and transformer power supply to be reliable, grounded, or they may lead to reduced stability of the main controller.

Master controller and the layer of station communication connection (485 Communications)

The next row of the main controller plug terminals "J5-A, B" is the interface of the main controller and the layer of station communication.

Cable requirements:

It must be twisted-pair connections, besides, stranding pitch is not greater than 30mm.

### 2.1.4 Terminal Description

Terminal No.	Input / Output Type	Function	Description
AC12V	Input	Power Input	Voltage permissible range: AC12V ± 0.5V

V+	Output	Power output and input signal common terminal	
0V	Output	Power output negative	
Z1—Z8	Input	Floor sensor input	Normally Open
JT	Input	Safety circuit relay	Normally Open
MJ	Input	Lock circuit relay	Normally Open
ZL	Input	Feedback brake and output contactors	NC
XW	Input	Lower bit	NC
SW	Input	Maximum bit	NC
MS	Input	Maintenance slower function	Normally Open
MX	Input	repair the function of “Slow down ”	Normally Open
JX	Input	Maintenance	Normally Open
A	Communications	Serial Data Communication	
B	Communications	Serial Data Communication	
T	Output	The station clock output	
MC	Output	Master contactor output	
SC	Output	Upstream contactor	
XC	Output	Downstream contactor	
NC		Standby terminal	

## 2.2 Auxiliary Board Help

### 2.2.1 Functional Overview

To simplify the elevator control cabinet structure, improve stability and reduce costs, our company designed and developed a special electronic elevator control circuit board, it is JR-ASB auxiliary board. Its main features are: used Brand substrate seal replaces the conventional plug-in relay latching relay, and phase sequence detection circuit, rectifier filter circuit and most of the control circuit integrated in a circuit board.

### 2.2.2 Dimensions and components description

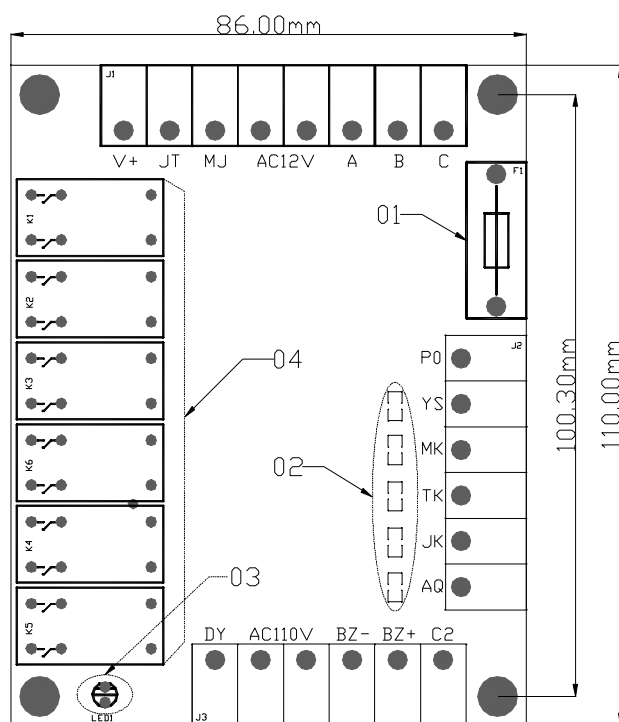

Code	Name	Uses Introduction	Notes
01	2A fuse	Short-circuit protection of the contactor control circuit	
02	Input Indicator	Instructed to enter of the state	
03	Phase Sequence Indicator	If the green light is lit it means that the phase sequence to normal, if the green light is dark it means missing out phase or the wrong phase	
04	Relay	It includes the power lock relays, safety relays, door lock relay, phase sequence relay, limit relays, safety gear relays.	

### 2.2.3 Terminal Description

Terminal No.	Input / Output Type	Function	Description
AC12V	Input	Power Input	Vol tage permissible range:



			AC12V $\pm$ 0.5V
V+	Input	JT, MJ output common terminal	
JT	Output	Safety circuit relays (normally open points)	Normally Open
MJ	Output	Lock circuit relay (normally open points)	Normally Open
A	Input	AC 380V-A	
B	Input	AC 380V-B	
C	Input	AC 380V-C	
PO	Output	Input common terminal	
YS	Input	Key Switch	Normally Open
MK	Input	Door loop	Normally Open
TK	Input	Safety loop	NC
JK	Input	Limit Switches	NC
AQ	Input	Safety gear	NC
DY	Output		Connect the master board power supply terminal
AC110V	Input		AC 110V Input
BZ+	Output	DC 110V Cathode	
BZ-	Output	Negative DC-110V	
C2	Output		Connect contactor coil circuit

#### 2.2.4 Internal logic and external connections

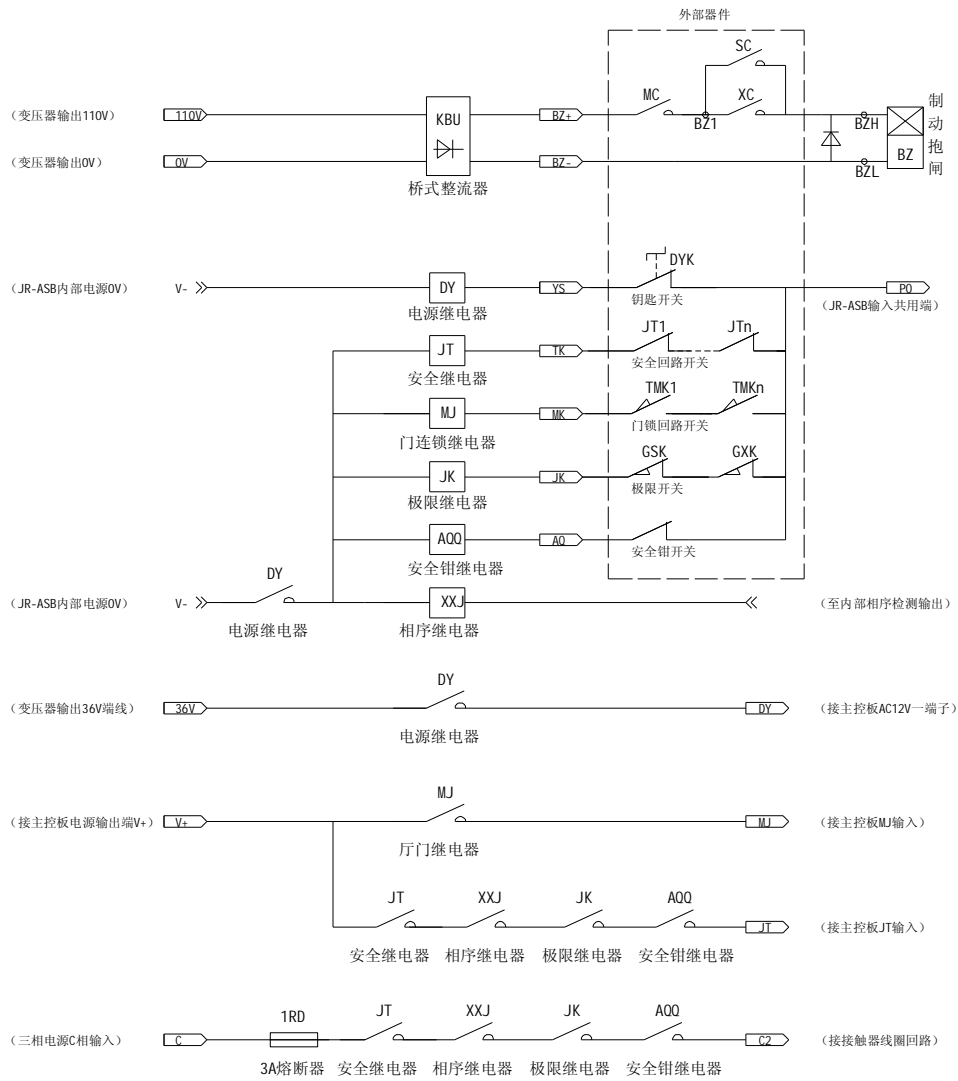

## 2.3 The panel part of the explanation

### 2.3.1 The internal structure of the Control Panel

Specific list of names is as follows

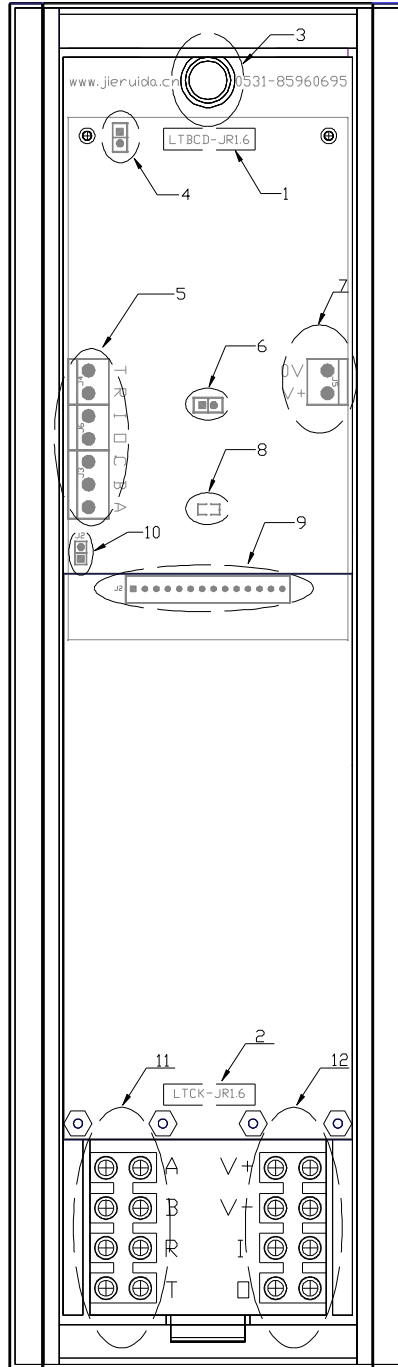

Code	Name	Uses Introduction	Notes
1	Floor Monitor LTBCD-JR	Shows the elevator's running, provides power for LTCK-JR t, and connects with the main controller	It has been installed on the injection panel
2	LTCK-JR	To implement a touch	It has been installed on the

	Touch button command controller LTCK-JR	function, Process and communicate with the host controller information, control the floor monitor's status	injection panel
3	Receiver	Turns the sound signals into electrical signals	It has been installed
4	Receiver socket	Connects the receiver	It has been connected to the receiver
5	Signal plug-seat	Connects Serial communications , intercom and emergency-stop with the outside world	It has been connected to the 11,12
6	Speaker sockets	Connects with the Speaker	It has been connected to the speaker
7	Power Access Block	Has access to an external power supply	It has been connected to the 11,12
8	Communication Indicator	Directs the communication status	
9	Pin plug	To achieve the connection LTBCD-JR with LTCK-JR	It has plug-in
10	Termination resistor	To set-off the communication terminal resistor	Primary station (usually the first one layer) is in a short-circuit connection, the other floors are placed in a disconnected state
11 12	Pressure Line terminal row	To achieve the transition with other components and connectors (5,7)	

Schematic diagram of the internal structure of the Control Panel

### 2.3.2 Connection Method

Users only need to be completed in accordance with circuit voltage line terminal row (11,12) and external connections .

2.3.3 Terminal Description

Terminal No.	Input / Output Type	Function	Description
V+	Input	Positive Power Input	
V-	Input	Negative Power Supply Input	
A	Communications	Serial Data Communication	
B	Communications	Serial Data Communication	
R		Intercom cable	
T		Intercom transmission and the station clock input	
I	Output	E-STOP relay output	NC
O	Output	E-STOP relay output	NC

III System circuit

3.1 Main circuit diagram

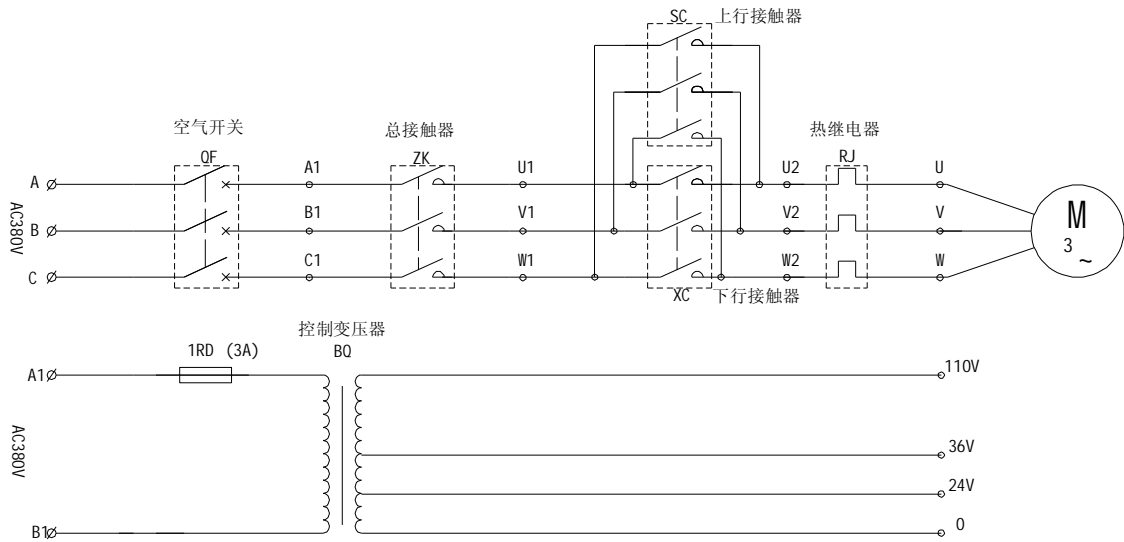

3.2 Auxiliary board wiring diagram

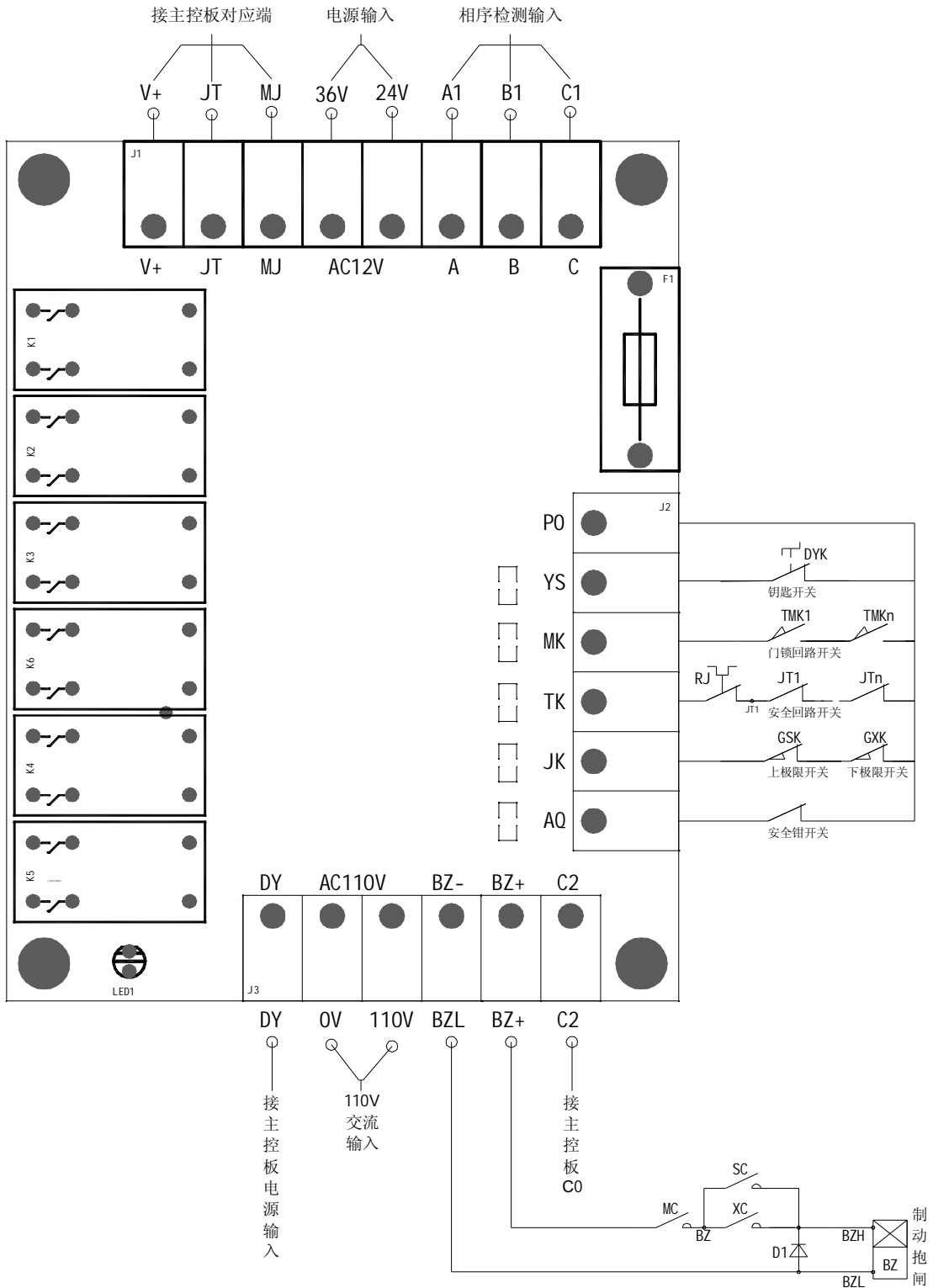

3.3 Control circuit diagram

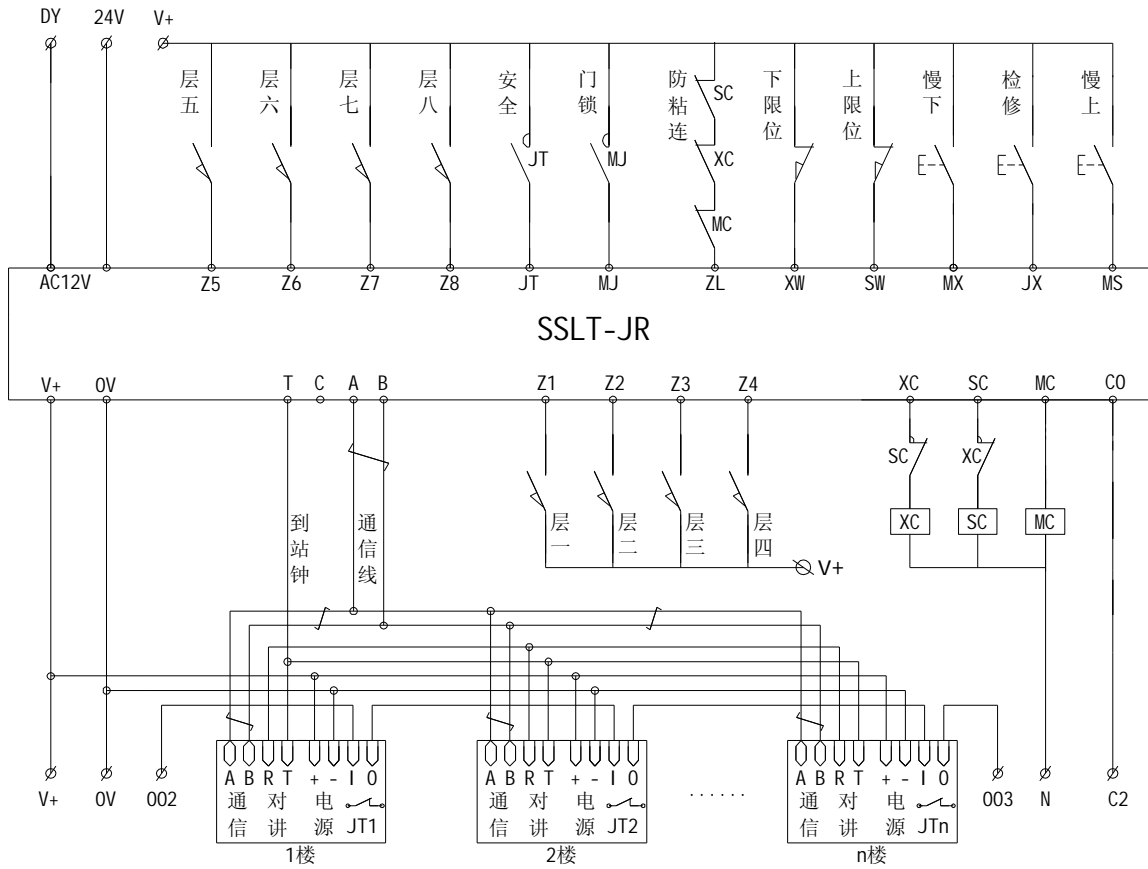

3.4 The control cabinet layout diagram

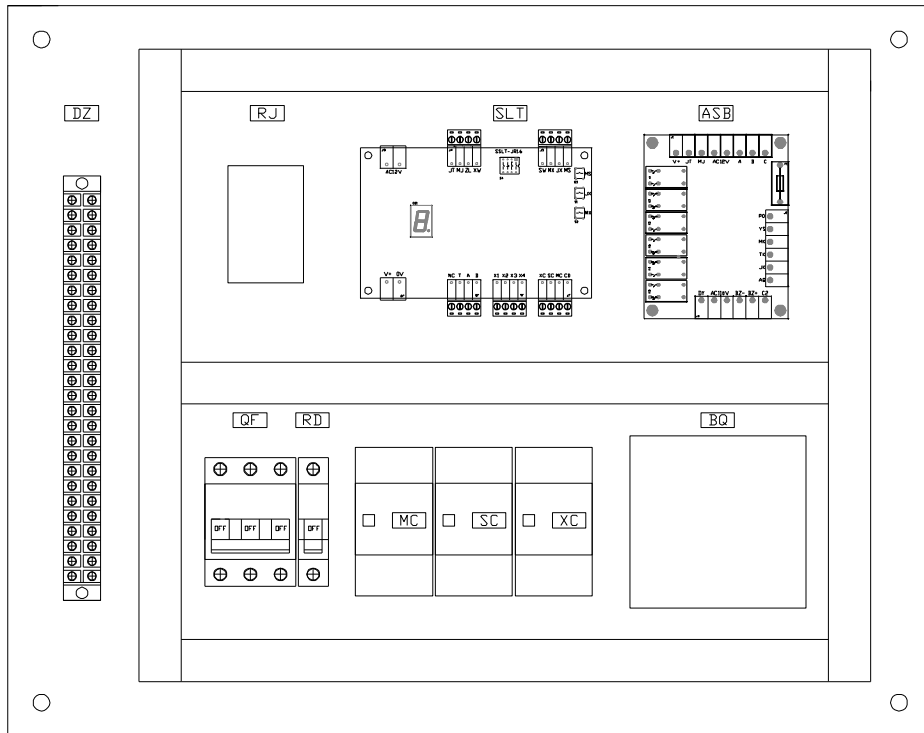

## 3.5 Configuration control cabinet list

Symbol	Name	Model	Notes
QF	3 pole Miniature Circuit Breaker (circuit breaker)	DZ47-63-D	6A-16A
RD	Pole MCB(circuit breaker)	DZ47-60	3A / fuse
BQ	Control Transformers	BK150-200	Output 110V, 36V, 24V, 6V
RJ	Thermal relay	JR36-20	Set the value is 1.2 times of the motor rated current
ZK、SC、XC	Contactors	CJX1-9~140	
SLT	Host Controller	SSLT-JR1.8	
ASB	Auxiliary Board	JR-ASB	
DZ	Terminal row	1530	
D1	FWD	FR307	Fast Recovery Diode 3A/700V

## 3.6 Terminal control cabinet wiring diagram



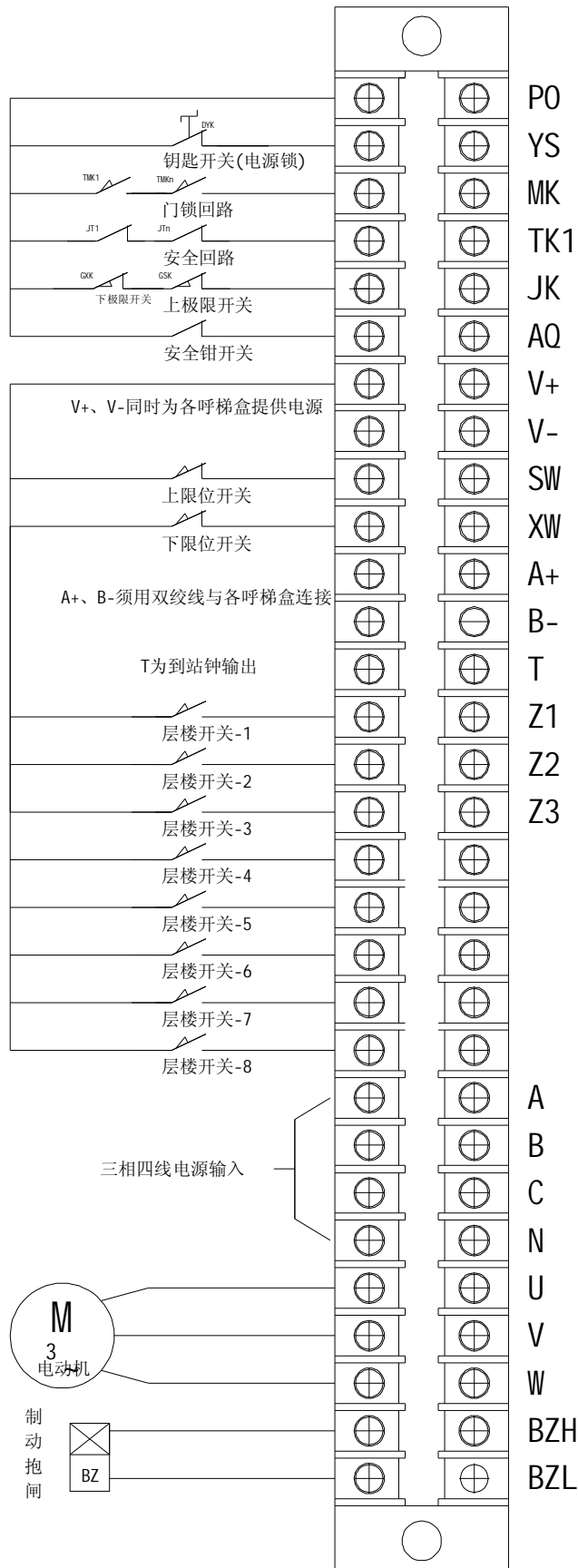

### 3.7 Control Cabinet Terminals Description

Terminal No.	Input / Output Type	Function	Description
V+	Output	Common external input and output power supply positive terminal	
OV	Output	Output Power Negative	
Z1-Z8	Input	Floor sensor inputs (normally open points)	Normally Open
A+	Communications	Serial communication line	
B-	Communications	Serial communication line	
T	Output	Arrival Bell	
SW	Input	Upper limit position switch(NC)	
XW	Input	Upper limit position switch	
PO		Input common terminal	
YS	Input	Key Switch	Normally Open
MK	Input	Door loop	Normally Open
TK	Input	Safety loop	NC
JK	Input	Limit Switches	NC
AQ	Input	Safety gear	NC
A	Input	AC 380V-A	
B	Input	AC 380V-B	
C	Input	AC 380V-C	
N	Input	AC power neutral line (zero line)	
U	Output	Motor Power Supply	
V	Output	Motor Power Supply	
W	Output	Motor Power Supply	
BZH	Output	Brake brake Positive	
BZL	Output	Brake brake negative	

### 3.8 control cabinet installation dimensions

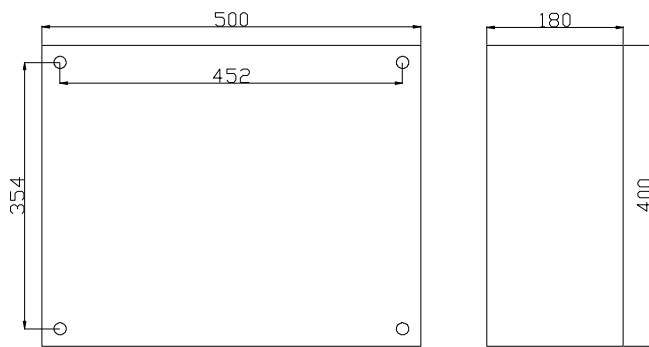

#### IV Commissioning and operation

Please carefully refer to the manual, complete the system connection. Determine the ground around the line-end has been reliable, all control circuit connections are correct and place the system immediately on maintenance status, then you can be power-debug. Please check before you focus on the power supply circuits.

##### 4.1 Initial power-on

After being power-on, if the car just stopped on a floor stand, then this level indicator will be in lit stations; if the car stops in a two-layer between the layer, selected layer lit up any **call-ladder instruction lamp**. **car will be down, find the nearest floor stop, and stop, and at this time the corresponding floor lamp will be lit.**

##### 4.2 Related Settings

###### 4.2.1 Main Control Board JR-SC-8 DIP-switch settings

Set Name	Functional Description	Set bit	DIP switch status	state of setting
Anti-adhesion door	In setting case, can monitor whether the door switch is adhesion. That is: Every time the station receives switch gate signals need to be allowed to continue selected layer.	4th		Not set
				Set
Running time-out protection	If the elevator is running longer than a single station setup time, take protection. At this point: Fault code	No. 2, 3 bit		60S
				28S

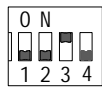
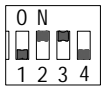
	displays F., control panel displays 1.			16S
				12S

4.2.1 Control Panel No. set

When the system is first on a power and running, set ID for each call Ladder box.

(Note: When the number is not set, it will display "0", this time all the commands lights will light up and can't communicate with the main control board).



The purpose of setting: set the number of each control panel, for example: the first floor of control panel sets to 1, the second floor control panel sets to 2.....

Setting Method: Touch intercom button and emergency stop button while rapid clicks (interval 0.5S) preset number button 8 times. For example: the second floor-based control panel numbered 2. In other words, touch intercom button and emergency stop button and hold while clicking on 2 key 8 times, this time panel digital display shows 2 and shows the same state with the main controller communication synchronization after two seconds ; after 10S it will normally operate .

4.2 .2 Code instructions

Direction rule: In the case of no failure, code instructions and floor shows to be synchronized, otherwise instructed fault code. If the decimal point digital tube light, this shows the failure code.

Fault code and Solutions

Fault code	Code Description	Synchronization instructions	Analysis of the causes
	Safety circuit breaker	Stop lights lit up	The main reason this happens is "the upper and lower limit switches, phase sequence relay, thermal relay, an emergency stop switch" action or the failure safety relays
	Door chain loop circuit	Open lamp lit up	Car doors or Door switch is not closed, it also could be the door chain relay fault

3.	Contactor adhesion	Stop lights lit up	The main contactor, upstream or downstream contactor appears adhesion or auxiliary contacts meet failure
4.	Action Limit Switch	The corresponding LED off	Maximum bit or lower bit something which can be determined based on the input LED
5.	Multi-input	Stop lights lit up	The reason is floor sensor failure or sensor short-circuit connection.
b.	Serial communication error		Control Panel Number is not set or set incorrectly, without the use of twisted-pair communication lines or terminal resistor is not set (For details, please refer to 2.1.1-10)
E.	Outbound time-out - 4S has been out of the current layer	Control Panel Flash 0	Elevator starts brake is not open, the current level sensor is failure or running path is blocked
F.	Run out (the specific settings please refer to 4.1.1)	Control Panel Flash 1	Brake brake is not fully open, sensor is malfunction, the path of running is hindered or single-station run time is set incorrectly.
H.	Running the wrong direction, or more points	Control Panel Flash 2	Phase sequence settings are not correct or control circuit wiring errors will lead to run in the opposite direction, and sensor failure will lead to more stations

#### 4.3 Code instructions

#### 4.4 Maintenance Running

When the lift needs repair or want to manipulate the elevators in the engine room, and at the same time press the maintenance button and up button or simultaneously press the maintenance button and the down button, to achieve the lift points, moving upstream or downstream. Should be explained that, in the maintenance state of the election call ladder layer failure.

#### 4.3 Troubleshooting

Fault code list of the elevator control system includes almost all of the common faults, when you repair the fault, please refer to the list carefully analyzed.

V Normal operation of the system

### 5.1 Select Layer Running

The length of elevator power's time is required to initialize 6S, that means manipulate it after 6 seconds.

Select layer operation: in the door chain loop, security, closed circuit complete failure and no other circumstances, touch-selected button.

Select Layer Success: Instruction lamps (selected floor lamp backlight touch keys) light up and maintain, direction indicator lights, elevator's running.

Automatic arrival: car door into the selected area floors, elevators stop running, direction indicator light is off, lights off command, the station bell ringing. Then a selection layer operation complete.

Related Note: If you set the door of the anti-adhesion function (please refer to 4.1.1), after stopping at the station, you must switch doors can be re-elected layers. On the contrary, if it is not located, there is no need to switch the door, then you can re-selected.

### 5.2 Smart Intercom

Intercom operation: you only need to touch intercom button and the desired floor button call, this time you can leave your fingers.

Intercom Created: all floors intercom button lit backlight, the caller called floor button backlight flashing, called party call floor button backlight blinks.

Intercom End: after the establishment of intercom system, it automatically enters into the countdown procedure - 30S automatic hang up, or not yet reached 30S touch intercom button again when the end of a second manual intercom.

Related Note: In the case of touch intercom button not leaving, touch the called floor button, at this point the election will not be carried-layer functions.

**Jinan Jieruida Automation Ltd.**

Address: Jinan City, Shandong Province, Ji  
Qi Road, No. 136

Sales Inquiries: (0531) 85960695

Technical Advisory: (0531) 55500695

Website: <http://www.jieruida.cn>

E-mail: [6666@jieruida.cn](mailto:6666@jieruida.cn)